

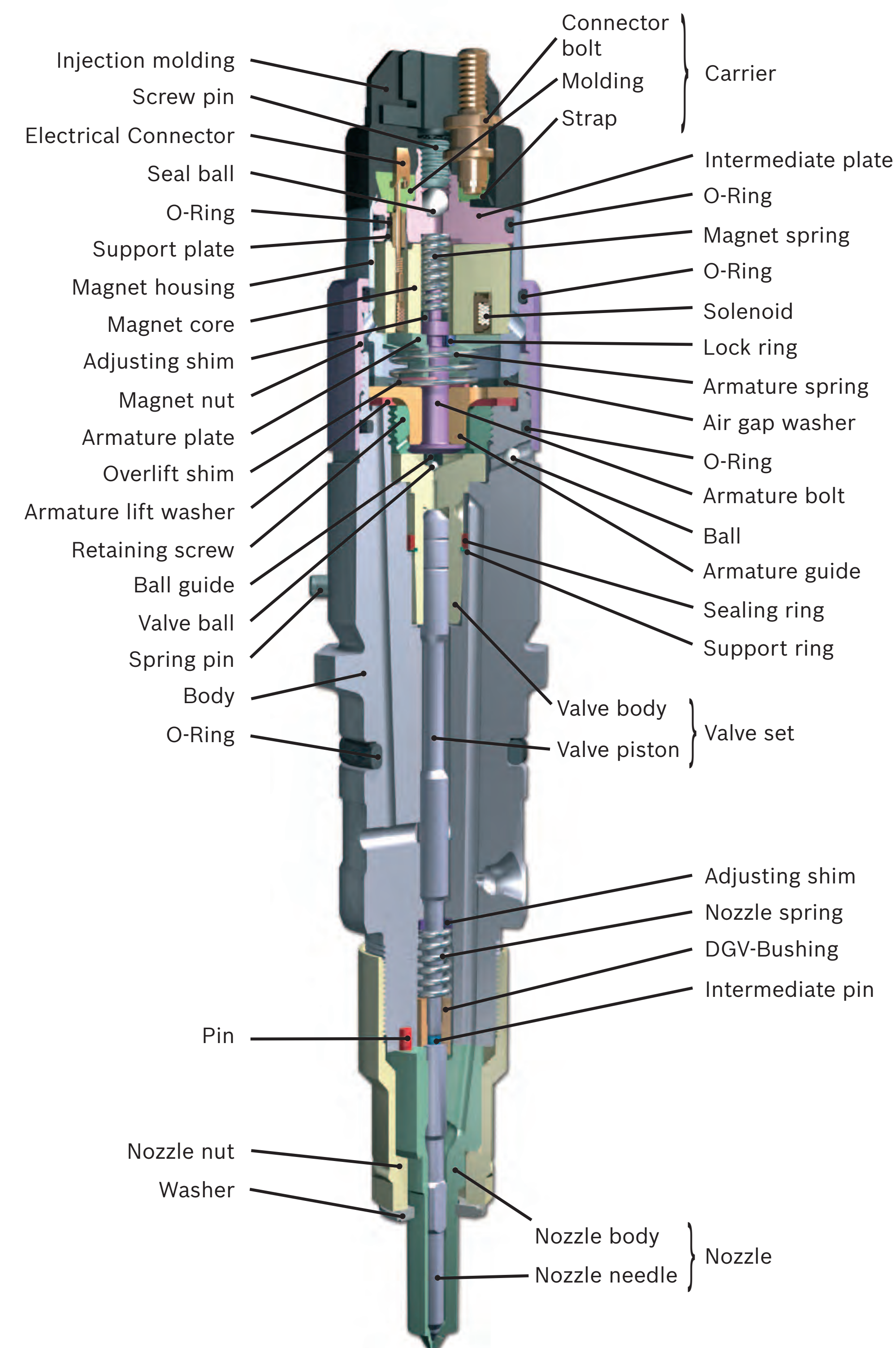

Solenoid valve injector

System pressure up to 1600 bar

► Type: CRIN 1



Customers: Cummins, Isuzu

Armature

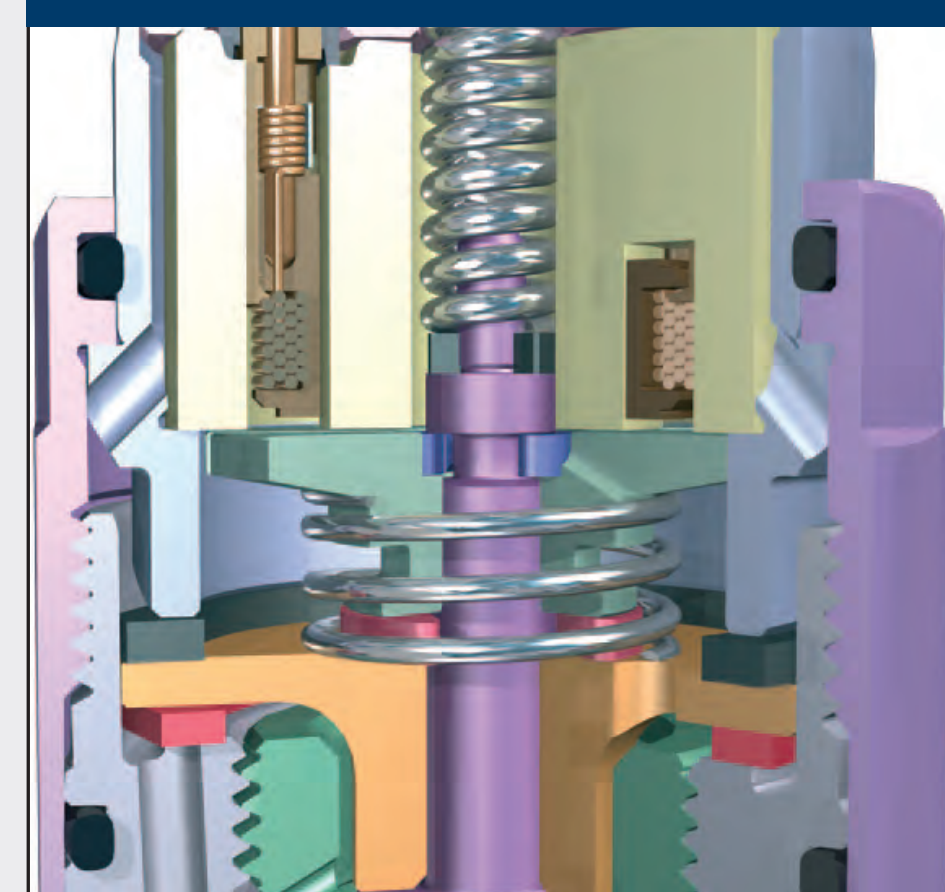

Valve Body

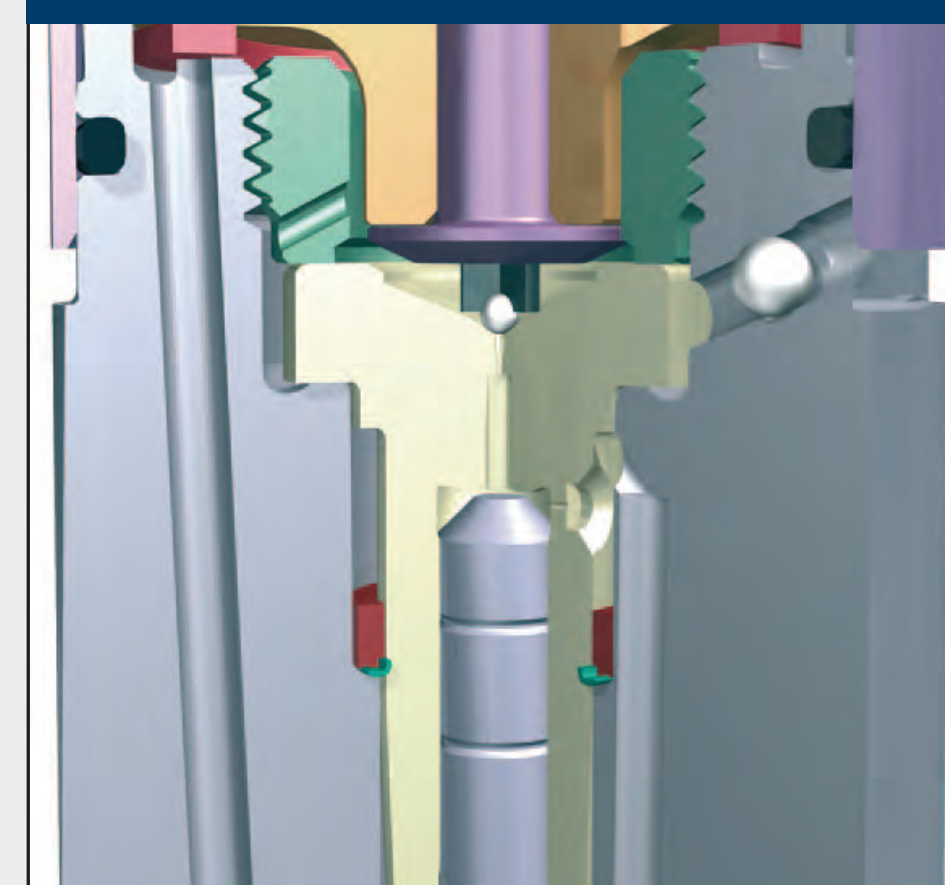

Solenoid valve injector

System pressure up to 1800 bar

► Type: CRIN 2

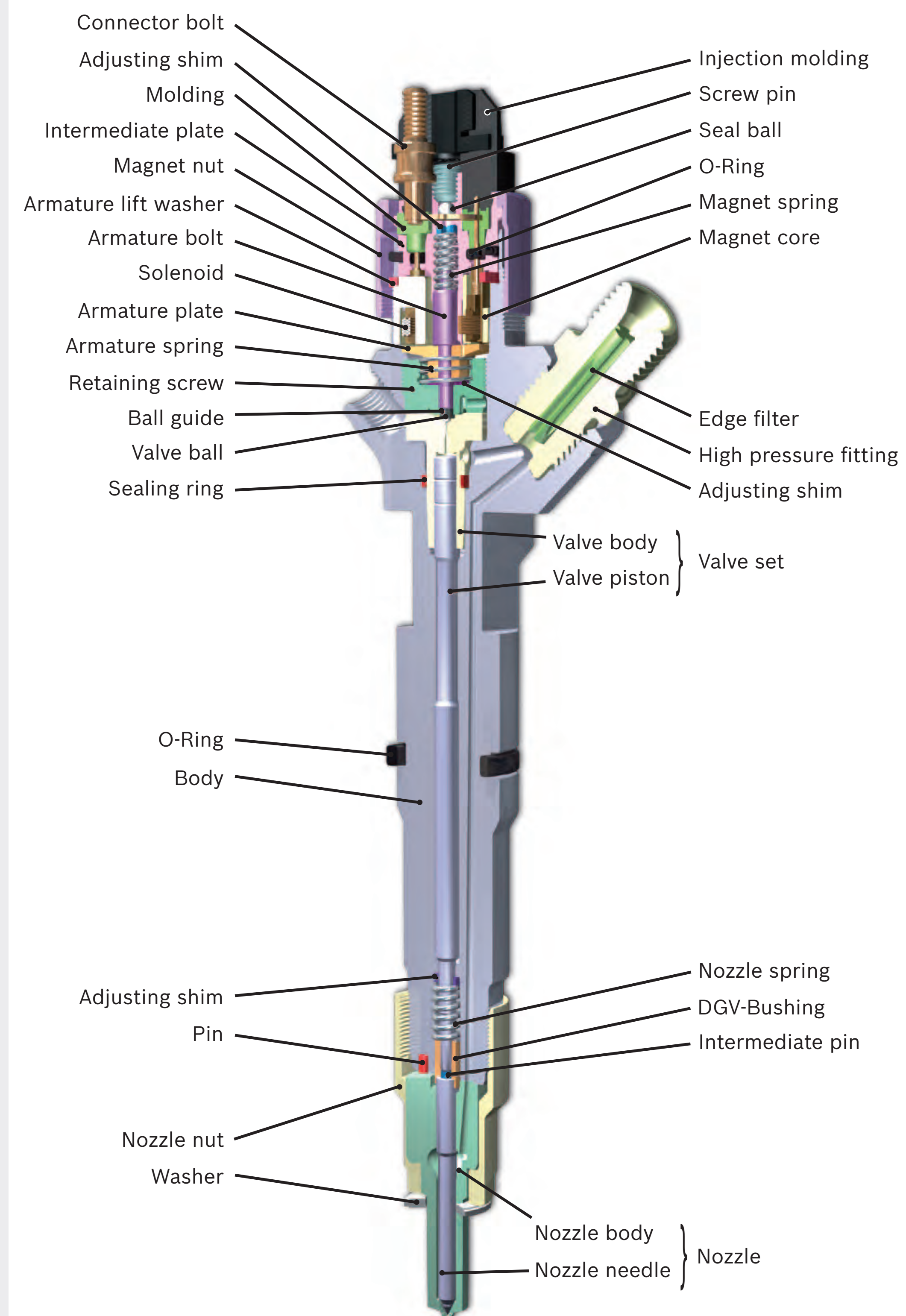

Customers: Isuzu

Armature

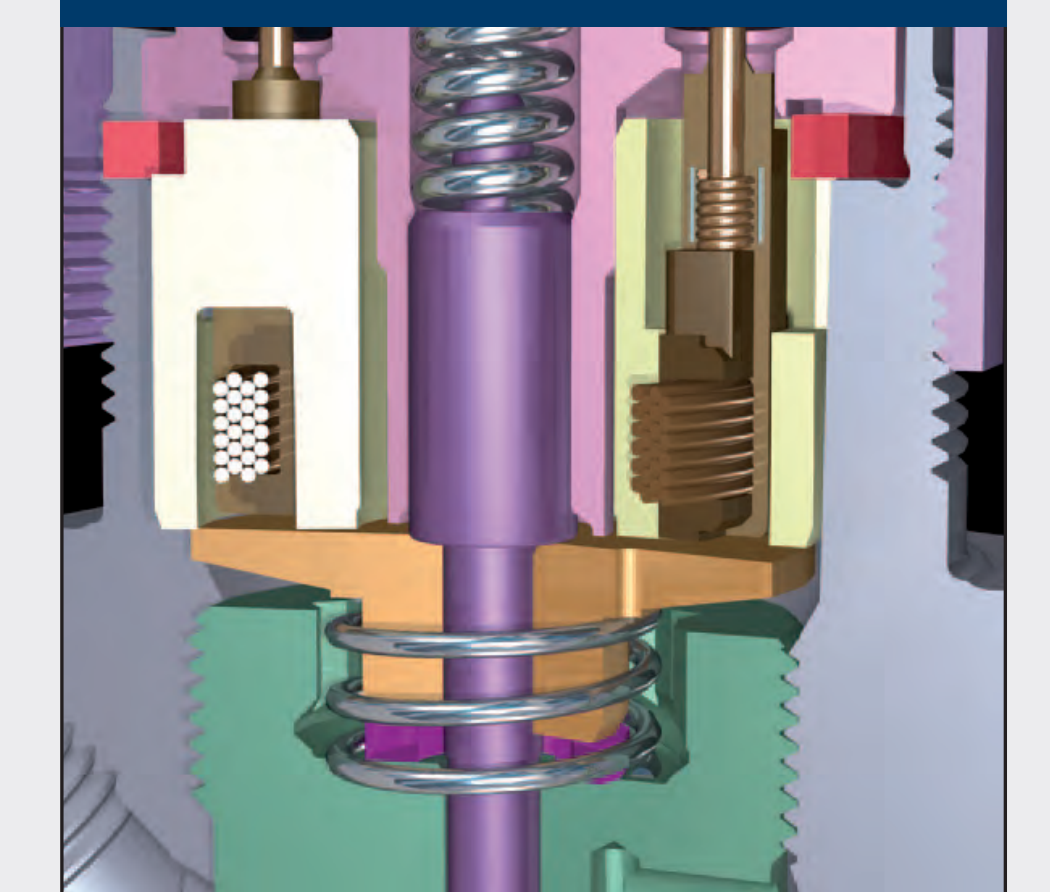

Valve Body

